



Project _____

AIA # _____ SIS # _____

Item # _____ Quantity _____ C.S.I. Section 114000



OV310G Mini Rotating Rack Convection Oven – Gas



Shown with optional 12 pan stand



SPECIFIER STATEMENT

The oven shall be of stainless steel construction, manufactured in the United States by Baxter Mfg. The unit footprint shall be no wider than 48.0" and shall be capable of fitting through a standard 36" doorway. The standard digital control panel shall have 99 programmable settings with auto on/off feature and 4-step bake/roast setting. As a standard feature, the oven shall incorporate "sleep" settings to save energy when not in use.

The oven shall include an in-shot burner system with a heat exchanger consisting of 8 independent high-temperature, corrosion resistant, weldless, stainless steel tubes. The in-shot burners will have no moving parts. The oven shall also have an interior carrier that rotates while in operation to ensure even baking. The interior carrier shall be easily removable for cleaning and routine maintenance, no tools required.

The oven will bear the following agency approvals: UL for safety and sanitation for the U.S., Canada, and Commonwealth of MA. The oven shall be certified for zero clearance to walls from UL.

The oven shall be offered with several different base options to ensure a combination best suited to site, production and operator's needs.

STANDARD FEATURES

- + 95,000 BTU/Hr. in-shot burner system
- + High-temp stainless steel heat exchanger with weldless construction for longer life; tubes carry an additional 9-year extended parts & labor warranty
- + Rotating interior rack
 - 8 pan, end load with 4.0" slide spacing
- + Interior rack is easily removable for cleaning and routine maintenance
 - Patented removable rack bottom for spot cleaning bake chamber floor
- + Self-contained patented steam system
- + Programmable digital control
- + Easy to open independent doors
- + Large dual-pane viewing window in each door
- + Space saving 48.0"w x 38.1"d footprint
- + Stainless steel construction
- + Cable restraint kit
- + Shipped assembled

OPTIONS & ACCESSORIES

- Removable interior rack, one included with oven, use accessory code to order additional racks:
 - 310RCK-6EL:** 6-pan capacity with 5.3" slide spacing, end load
 - 310RCK-6SL:** 6-pan capacity with 5.3" slide spacing, side load
 - 310RCK-6STP:** 6-pan capacity with 5.3" spacing and stepped slides, end load
 - 310RCK-8EL:** 8-pan capacity with 4.0" slide spacing, end load
 - 310RCK-8SL:** 8-pan capacity with 4.0" slide spacing, side load
 - 310RCK-8STP:** 8-pan capacity with 4.0" spacing and stepped slides, end load
 - 310RCK-12EL:** 12-pan capacity with 2.8" slide spacing, end load
- Flexible gas hose with quick disconnect
- Natural gas for altitudes above 6,500'
- Direct vent package (gas models only)
- Vent guard package – adds 2" to overall width
- MB300:** 34"h proofing cabinet base
- STAND:** 27"h stand base with 12 pan capacity
- Slide bridge kit allows oven to accommodate pans smaller than 18" x 26"
- Aluminum tray set for artisan baking includes 4 trays
- Peelkit includes 4 each wooden peels 14" long used with aluminum trays

Note: Capacities based on a standard 18" x 26" pan

OV310G MINI ROTATING RACK CONVECTION OVEN – GAS

Approved by _____ Date _____ Approved by _____ Date _____



OV310G

Mini Rotating Rack Convection Oven – Gas

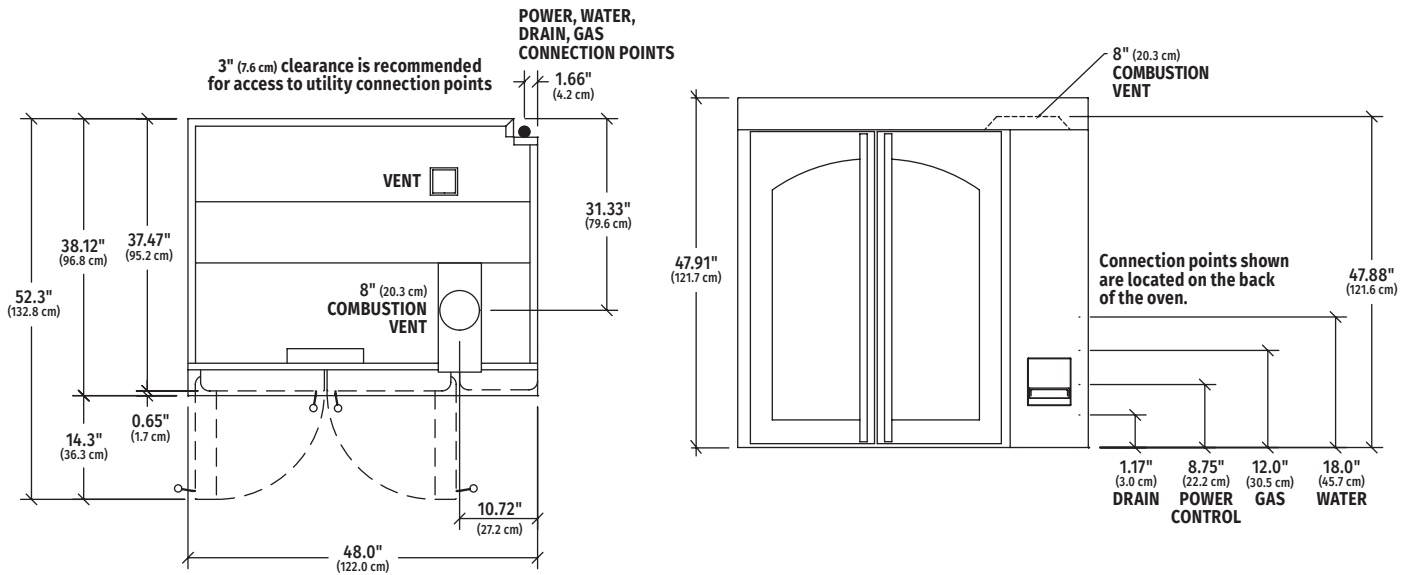

Shipping Weight: 785 lbs. (356kg) **Rack Swing Diameter:** 31.5" (80cm) **Maximum Door Swing:** 115° (right)/180° (left)

UTILITIES

Gas Connect Point: 3/4" FNPT 95,000 BTU/Hr

- **Standard:** Natural Gas @ 5" to 14" w.c.
- **Optional:** Propane Gas @ 11" to 14" w.c.

Note: Input rates will be reduced when oven is installed at elevations above 3,000' (915m). Contact factory for elevation correction.

Drain Fitting: 1/2" MNPT. Route to air-gap drain.

Power: 120V/60/1 15 amp maximum dedicated circuit. 8' cord and NEMA 5-15 Plug supplied. Contact factory for 50Hz.

- **Oven Control:** 6.6 amps
- **Exhaust Fan Connect Point:** 5.0 amps maximum

Water Connect Point: 1/2" FNPT. Cold water @ 30-75 psi. minimum @ 1.5 G.P.M. flow rate. 3.0 G.P.H. maximum water usage.

Note: Water supply must have the proper hardness, pH & chloride concentration. Consult your local water company and/or water conditioner dealer before installation.

- **Recommended hardness range:** 2-4 grains per gallon.
- **Recommended pH range:** 7.0-8.0.
- **Acceptable range for chloride concentration:** 0-30 ppm.

Standard Venting: Oven to be installed under an exhaust hood to vent by-products of combustion. A Type I (grease) or Type II (vapor) exhaust hood may be required. Consult local codes.

Direct vent option: 8" diameter connection. Draft diverter provided. Ducting and fan (if required) to be supplied by others per local and state codes. Draft of 50 c.f.m. (-.03"w.c. to -.11"w.c.) required at a point 6" above diverter upper collar. Exhaust hood may also be required. Consult local codes.

INSTALLATION

The mini-rack oven is shipped assembled for easy installation. All components are factory tested before shipment. This oven must be installed so that the top of the oven is located above 6' AFF.

The purchaser is responsible for proper installation. In order to validate the warranty, the start-up must be performed by an Authorized Baxter Servicer.

The OV310 unit will fit through a standard 36" doorway with doors, control panel, trim package, and draft inducer removed.

UL Listed for use only on level, noncombustible floor/surface. Access to right side needed (24" minimum) for service access. A vent guard is required if the right side of the oven is within 30" of a radiant heat or grease vapor source.