



Project \_\_\_\_\_  
 AIA # \_\_\_\_\_ SIS # \_\_\_\_\_  
 Item # \_\_\_\_\_ Quantity \_\_\_\_\_ C.S.I. Section 114000



# INGREDIENT BIN



**Approved for  
Single Compartment**

## SPECIFIER STATEMENT

Ingredient Bins shall be constructed of fully welded stainless steel and include a sliding cover with sanitary corner design. The bin shall use 3" non-marking casters with two fixed and two swivel.

## STANDARD FEATURES

- + Stainless steel all-welded bin with sliding cover
- + Sanitary cover corner design eliminates the need for costly replacement liners
- + Approximate capacity of 120 lbs. (54kg) of cake flour or 190 lbs (86kg) of granulated sugar
- + Sturdy 3" non-marking casters (2 fixed and 2 swivel) require no lubrication
- + Moves easily when fully loaded
- + Divided compartments conveniently separate ingredients within one mobile unit

## MODEL CONFIGURATION

MODEL	DESCRIPTION	Weight
INGBIN-1CMPT1	1 Compartment bin, packaged 1 to a box	40 lbs/18.1kg Frt cl 150
INGBIN-1CMPT2	1 Compartment bin, packaged 2 to a box	80 lbs/36.3kg Frt cl 100
INGBIN-1CMPT3	1 Compartment bin, packaged 3 to a box	120 lbs/54.4kg Frt cl 92.5
INGBIN-1CMPT4	1 Compartment bin, packaged 4 to a box	160 lbs/72.6kg Frt cl 85
INGBIN-2COMPT	2 Compartment bin, packaged 1 to a box	52 lbs/23.6kg Frt cl 150
INGBIN-3COMPT	3 Compartment bin, packaged 1 to a box	64 lbs/29.0kg Frt cl 150

Table Length	4' (1.2m)	5' (1.5m)	6' (1.8m)	8' (2.4m)	10' (3.0m)	12' (3.7m)
Maximum Bin Quantity	2	3	4	5	7	9

**Note:** Table must be 36" (91 cm) wide min. to accommodate ingredient bin below.

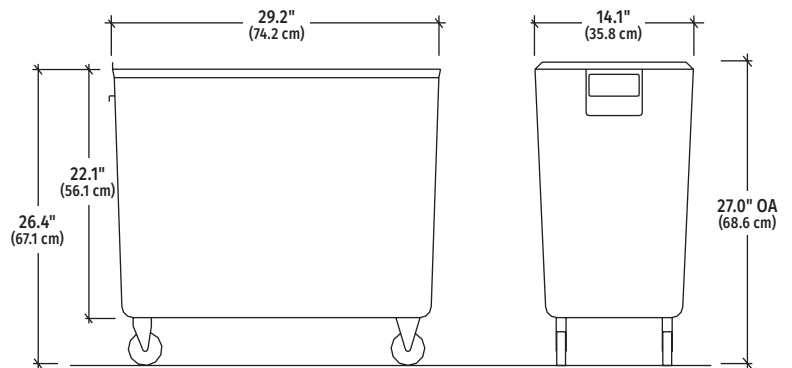

**INGREDIENT BIN**

As continued product improvement is a policy of Baxter, specifications are subject to change without notice.



Approved by \_\_\_\_\_ Date \_\_\_\_\_ Approved by \_\_\_\_\_ Date \_\_\_\_\_